

插座 DIN 43650

結構	電纜連接	線路圖	訂貨代號	
			黑色	灰色
插座 DIN 43650 結構形式 AF 防護級別IP65, 電壓至250V	PG9	圖1	5001710	5001711
	PG11		5001716*	5001717*
插座帶發光二極管-插件24V DC	PG11	圖1 和圖3	5001571	5001572
插座帶燈-插件120V AC 插座帶燈-插件230V AC		圖1 和圖4	5001573 5001575	5001574 5001576
插座帶發光二極管-插件24V DC和保護回路 插座帶整流器-插件 整流器帶接成橋式電路的4個硅二極管。在交流側的壓敏電阻保護二極管避免電源電壓峰值230V AC的衝擊。 插座帶應變釋放和透明罩	PG11	圖1 和圖5	5001708	5001709
		圖1 和圖6	5001737	5001738
		圖2	5001723	5001724
用于插座 5001723 和5001724的插件		線路圖	訂貨代號	
橋式整流器至230V AC 指示燈230V AC 橋式整流器帶指示燈120V AC 橋式整流器帶指示燈230V AC		7 4 8 8	5001727 5001730 5001733 5001734	

* 代號P的閥同元件插座一起供貨。

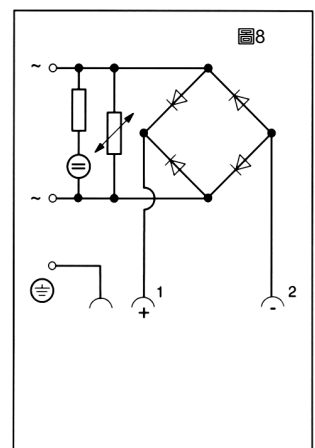
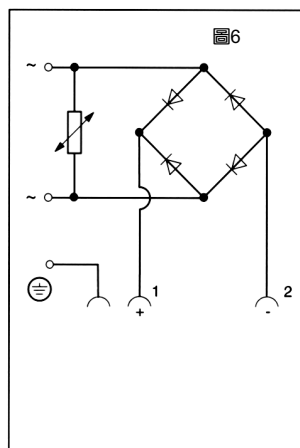
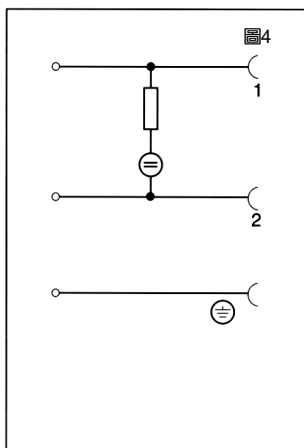
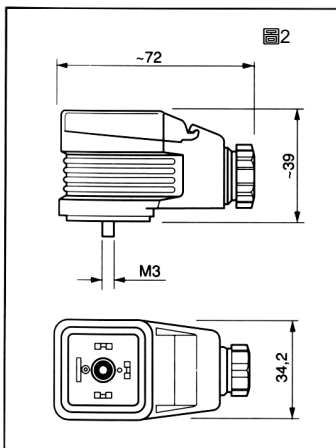
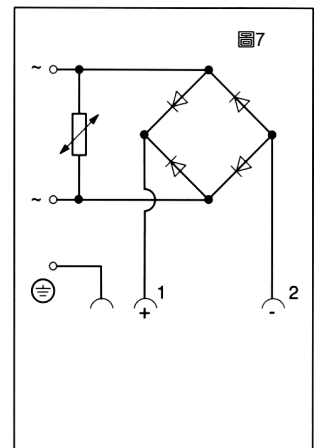
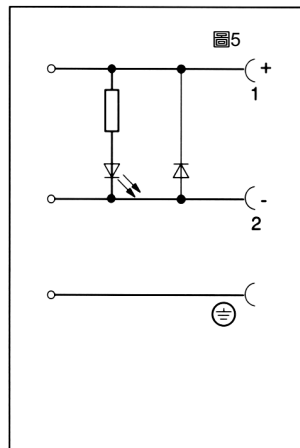
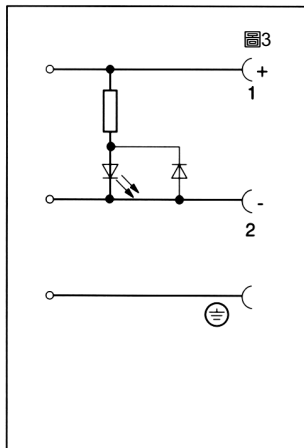
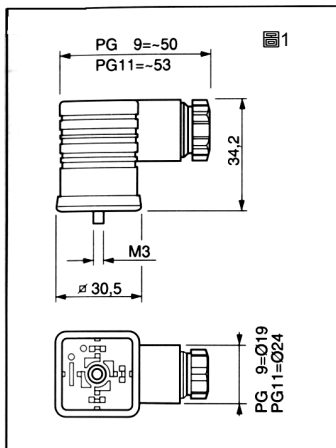

VBY-VMY A UK.PM6.5 RH

插座 M12 x 1, 接線盒

插座 M12 x 1

帶角度的插座 M12 x 1 是一種5針式結構，接口可以擰在插座上。
插座可以轉動 4 x 90°

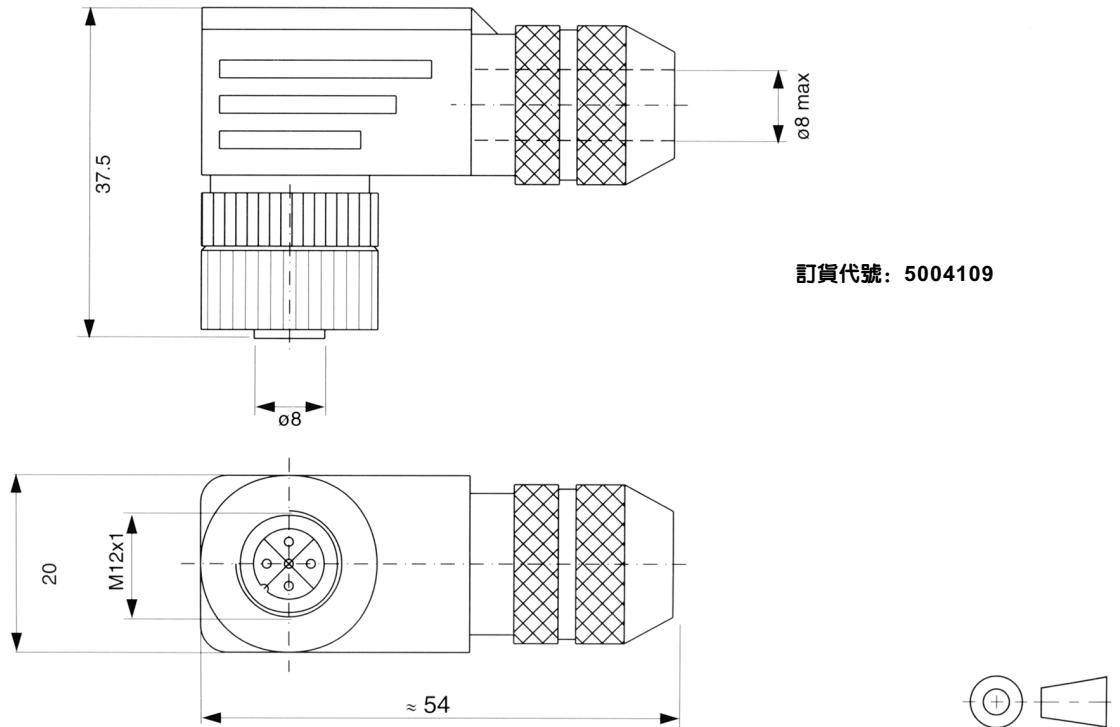

訂貨代號: 5004109

接線盒

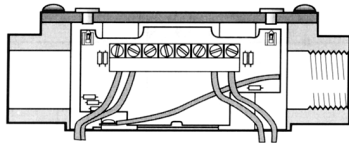

帶有顯示燈和接線端子
代號: C 和 5

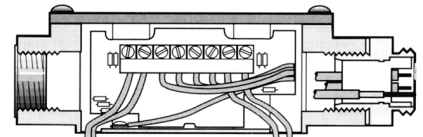

帶有 Brad Harrison 插頭外殼
代號: C 和 6

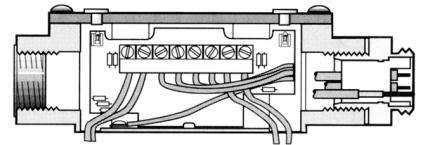
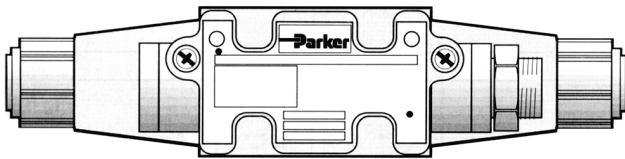

帶有顯示燈和 Brad Harrison 插頭外殼
代號: 5 和 6

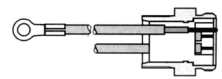
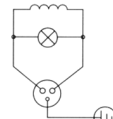
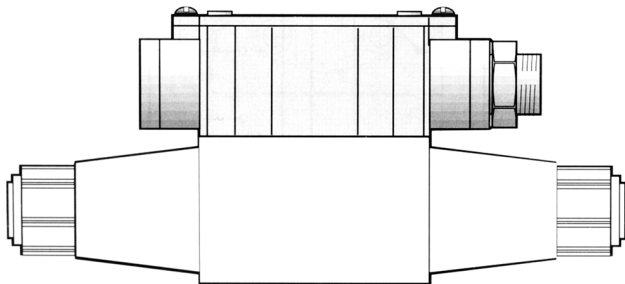

Brad Harrison 3針式

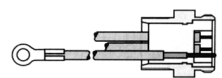
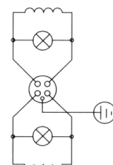

Brad Harrison 5針式

用于 D1VW/D1DW (不用于8W和柔和換向閥)

交流電磁鐵

直流電磁鐵

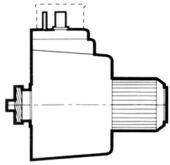

帶有插頭板 代號W

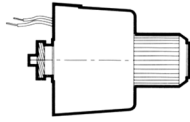

帶有活引綫 代號C

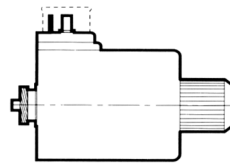

帶有插頭板 代號W



帶有活引綫 代號C

電壓 V/Hz	電壓代號	訂貨綫圈代號			銜鐵管訂貨代號		訂貨代號 螺母
		DIN插頭 D1VW(D3W)活引綫		DIN插頭 D1DW(D3DW)	T=105bar	T=210bar*	
12V= 24V= 98V= 196V=	K J U G	1301516 1301517 1301692 1301854	- 1301522 - -	1301762 1301761 1301763 1301764	697633	697717	1301609
110V/50Hz,120V/60Hz 220V/50Hz,240V/60Hz	Y T	702714/2S 702714/3S	702715/2S 702715/3S	- -	697632	697714	697981

對於D1VW-8W

*電磁鐵改型代號H

電壓 V/Hz	電壓代號	訂貨綫圈代號			銜鐵管訂貨代號 T=210bar	訂貨代號 螺母
		DIN插頭	M12 x 1	DESINA		
24V=	J	5004232	5004234	5004235	5004233	1301609

對於D1VW-柔和換向: 請問詢

對於 D3W/D3DW

電壓 V/Hz	電壓代號	DIN插頭 D3W	訂貨綫圈代號		DIN插頭 D3DW	銜鐵管訂貨代號		訂貨代號 螺母
			活引綫			T=105bar	T=210bar	
12V= 24V= 98V= 196V=	K J U G	1860152-K 1860152-J 1860152-U 1860152-G	1860156-K 1860156-J 1860156-U 1860156-G	1860156-K 1860156-J 1860156-U 1860156-G	-	1860163	1860167	
110V/50Hz,120V/60Hz 220V/50Hz,240V/60Hz	Y T	691750 693987	691740-1 691743-1	- -	1300666	1301710*	702743	

*電磁鐵改型代號H

其他的結構請問詢

O形圈和密封組件

用于連接面密封的O形圈（1件的訂貨代號）

閥的公稱尺寸	閥的型號	接口	尺寸 內徑φ×厚度	數量	丁腈橡膠的 訂貨代號	氟橡膠的 訂貨代號
DIN NG 6	D1V D1D	P,A,B,T X,Y	9.25 × 1.78	4	2-012 N 552-90	2-012 V 747-75
			4.47 × 1.78	2	2-008 N 552-90	2-008 V 747-75
DIN NG10	D3	P,A,B,T X,Y	12.42 × 1.78	5	2-014 N 552-90	2-014 V 747-75
			10.82 × 1.78	2	2-013 N 552-90	2-013 V 747-75
DIN NG16	D4	P,A,B,T X,Y	21.89 × 1.78	4	2-018 N 552-90	2-018 V 747-75
			10.82 × 1.78	2	2-013 N 552-90	2-013 V 747-75
DIN NG25	D8	P,A,B,T X,Y	29.82 × 1.78	4	2-122 N 552-90	2-122 V 747-75
			20.29 × 1.78	2	2-117 N 552-90	2-117 V 747-75
DIN NG25	D9	P,A,B,T X,Y	34.59 × 1.78	4	2-126 N 552-90	2-126 V 747-75
			20.29 × 1.78	2	2-117 N 552-90	2-117 V 747-75
DIN NG32	D11	P,A,B,T X,Y	53.57 × 1.78	4	2-227 N 552-90	2-227 V 747-75
			14.00 × 1.78	2	2-015 N 552-90	2-015 V 747-75

*每組的數量

密封組件（連接面和內密封）

閥的系列	材料	閥的規格和連接成孔的訂貨代號								
		D1V	D1D	D3	D3D	D31D	D4	D8	D9	D11
D**W 電動式	丁腈橡膠	SK-D1VW-70	SK-D1DW-75	SK-D3W-30	SK-D3DW-40	SK-D31DW-75	SK-D41VW-70	SK-D81VW-70	SK-D91VW-70	SK-D111VW-70
	氟橡膠	SK-D1VW-70	SK-D1DW-V75	SK-D3W-V30	SK-D3DW-40	SK-D31DW-V75	SK-D41VW-V70	SK-D81VW-V70	SK-D91VW-V70	SK-D111VW-V70
D**P 液動式	丁腈橡膠	SK-D1VP-70	-	-	SK-D3DP-35	-	SK-D41VW-70	-	SK-D91VW-70	SK-D111VW-70
	氟橡膠	SK-D1VP-70	-	-	SK-D3DP-V35	-	SK-D41VW-V70	-	SK-D91VW-V70	SK-D111VW-V70
D*L/LB 手動式	丁腈橡膠	-	SK-D1DL-75	-	SK-D3DL-35	-	SK-D4L-60	-	SK-D9L-60	-
	氟橡膠	-	SK-D1DL-V75	-	SK-D3DL-V35	-	SK-D4L-V60	-	SK-D9L-V60	-

換向閥 連接底板

公稱尺寸 6: 連接底板 DIN 24340-A6

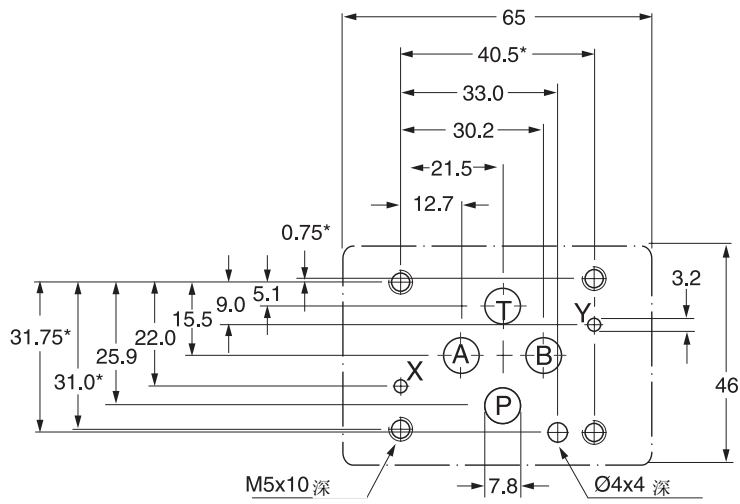

公稱尺寸 10: 連接底板 DIN 24340-A10

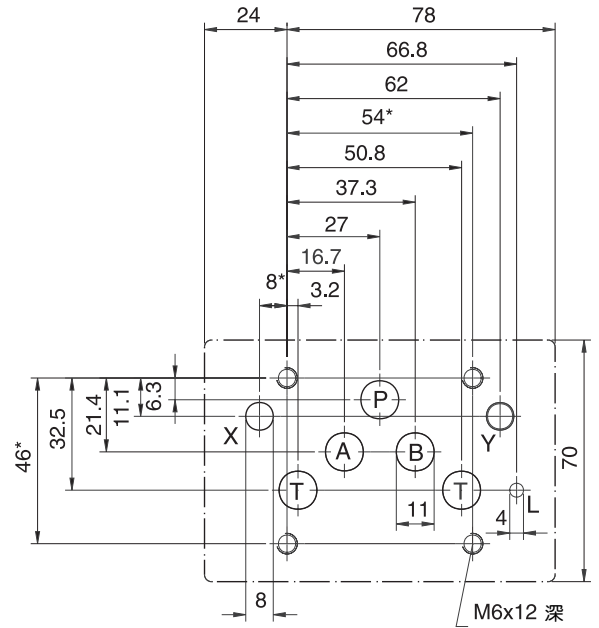

公稱尺寸 16: 連接底板 DIN 24340-A16

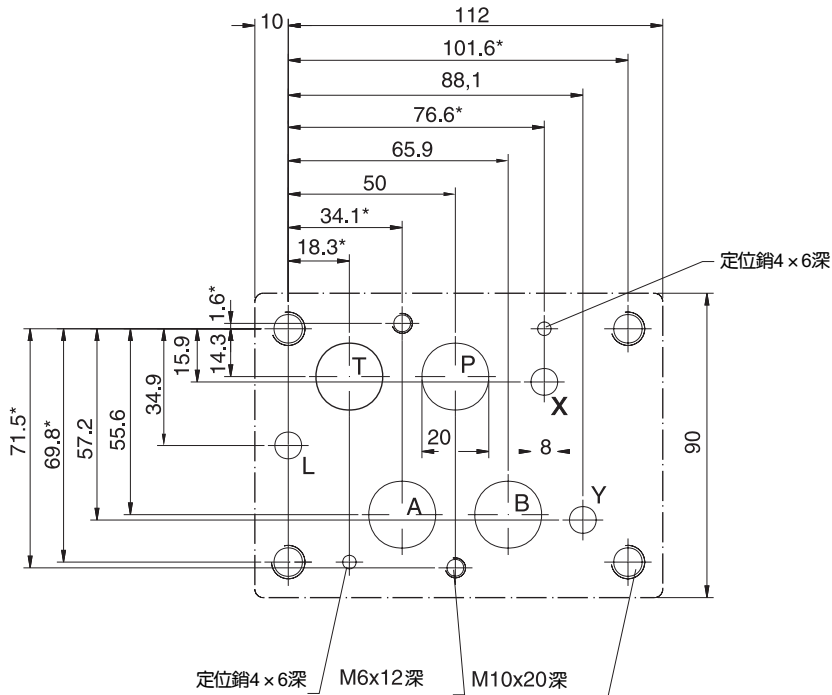

標有 * 的尺寸為 $\pm 0,1\text{mm}$ 的公差。
所有其他尺寸為 $\pm 0,2\text{mm}$ 的公差。

Lochbilde_gbr.PM6.5MM

換向閥 連接底板

公稱尺寸 25: 連接底板 DIN 24340-A25

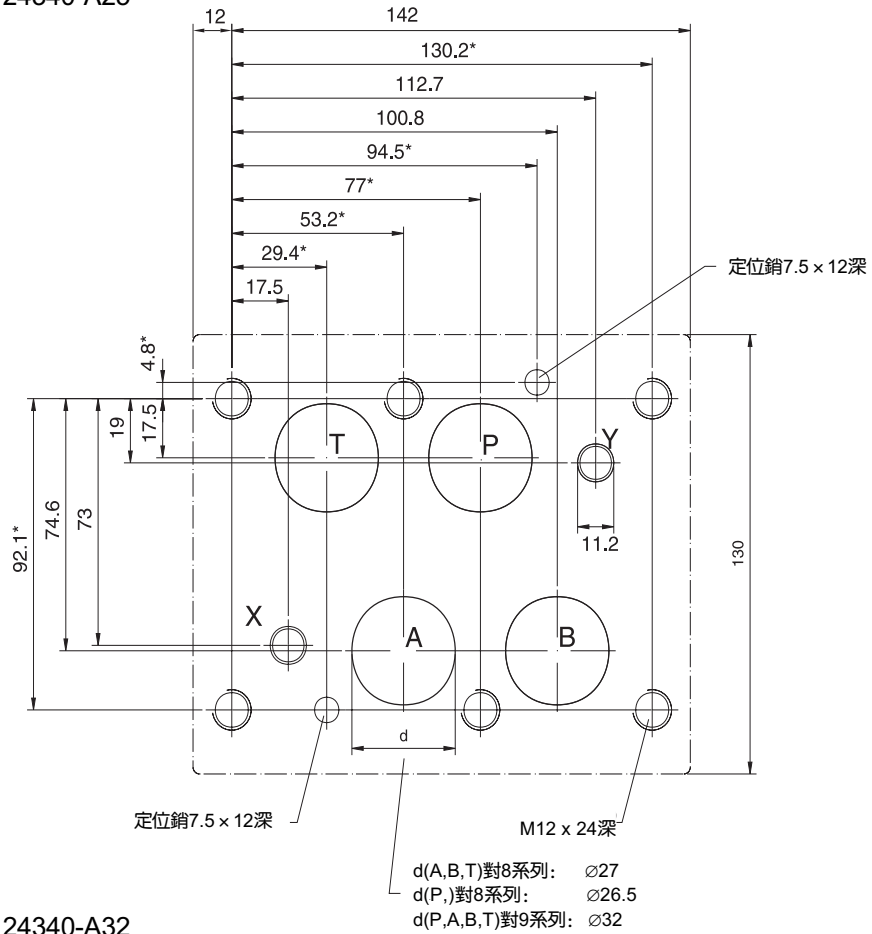

公稱尺寸 32: 連接底板 DIN 24340-A32

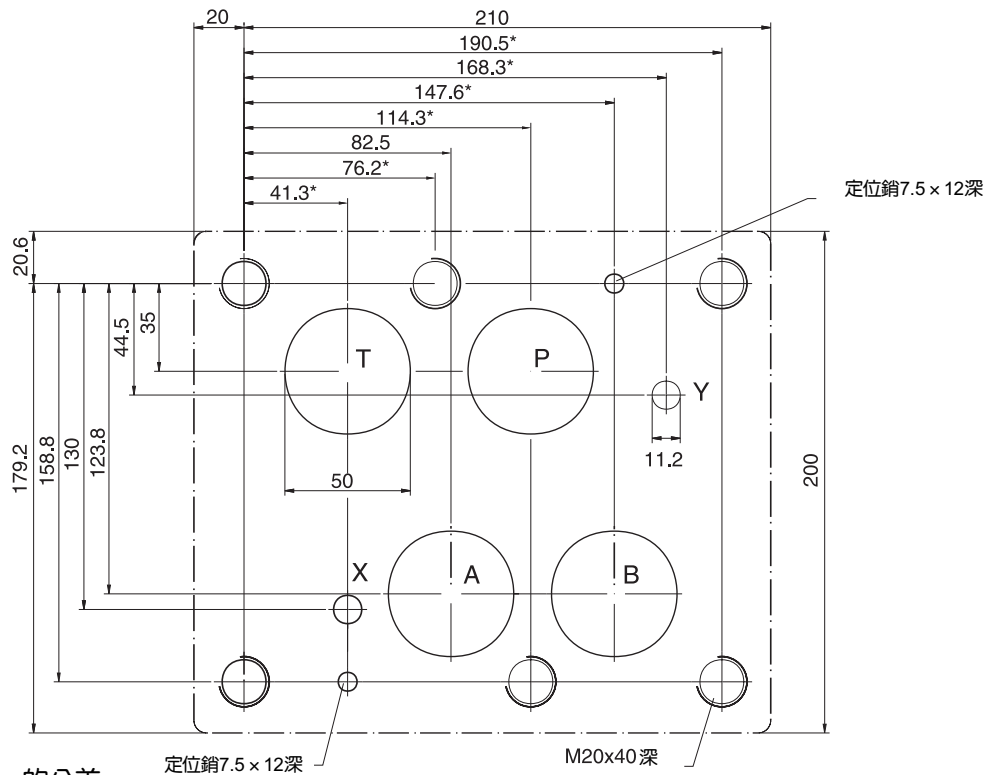

標有 * 的尺寸為 $\pm 0,1\text{mm}$ 的公差
 所有其他尺寸為 $\pm 0,2\text{mm}$ 的公差

Lochbilder_gb.PM6.5MM